

Model: 1012 - Z

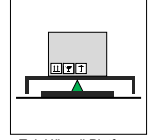

100 kg ... 500 kg



Tek Hücreli Platform

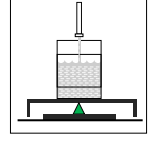

Dolum Uygulamaları

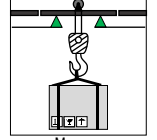

Monoray

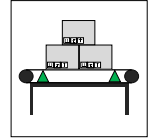

Konveyör Tartım

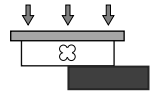

Ölçüler (mm)

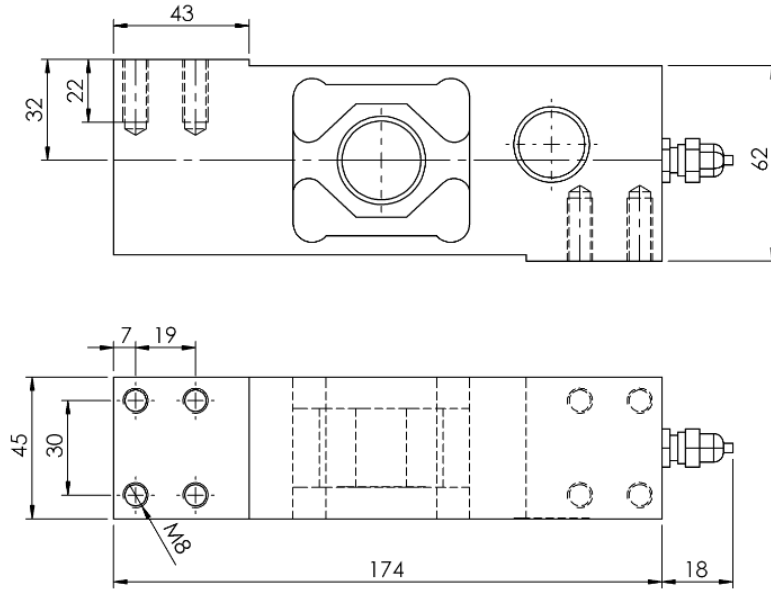

Kullanım Şekli / Montaj Aparatı

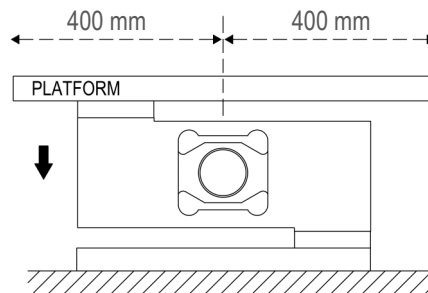

Teknik Özellikler

	Parametreler	Değer	Birim		
1	Nominal Kapasite (E_{max})	100, 150, 200, 300, 400, 500	150, 200, 250, 300, 400, 500	kg	
2	Sinyal Kazancı	2.0 ± 0.2		mV/V	
3	Doğruluk Sınıfı	C3	C4	C5	
4	$Y=E_{max}/V_{min}$	10,000	15,000	20,000	
5	Toplam Hata	$< \pm 0.023$	$< \pm 0,0175$	$< \pm 0,014$	%FSO
6	Sıfır Dengesi	$< \pm \% 2$		%FSO	
7	Sıcaklık Aralığı (Düzeltilmiş)	-10 ... +40		°C	
8	Sıcaklık Aralığı (Güvenli)	-35 ... +65		°C	
9	Güvenli Aşırı Yükleme	150		% E_{max}	
10	Kırılma kapasitesi	300		% E_{max}	
11	Besleme Gerilimi (Tavsiye)	18		V	
12	Platform Ölçüleri	400 x 400		mm x mm	
13	Giriş Direnci	$380 \pm 15 (<100t)$, $350 \pm 3.5 (100t)$,		Ω	
14	Çıkış Direnci	350 ± 3.5		Ω	
15	Yalıtım Direnci	> 5000		M Ω (100V)	
16					
17					
18					

(*) FSO = Full Scale Output

Kablo Özellikleri

Kablo Uzunluğu:3 m

Kablo Çapı:Ø5 mm

